

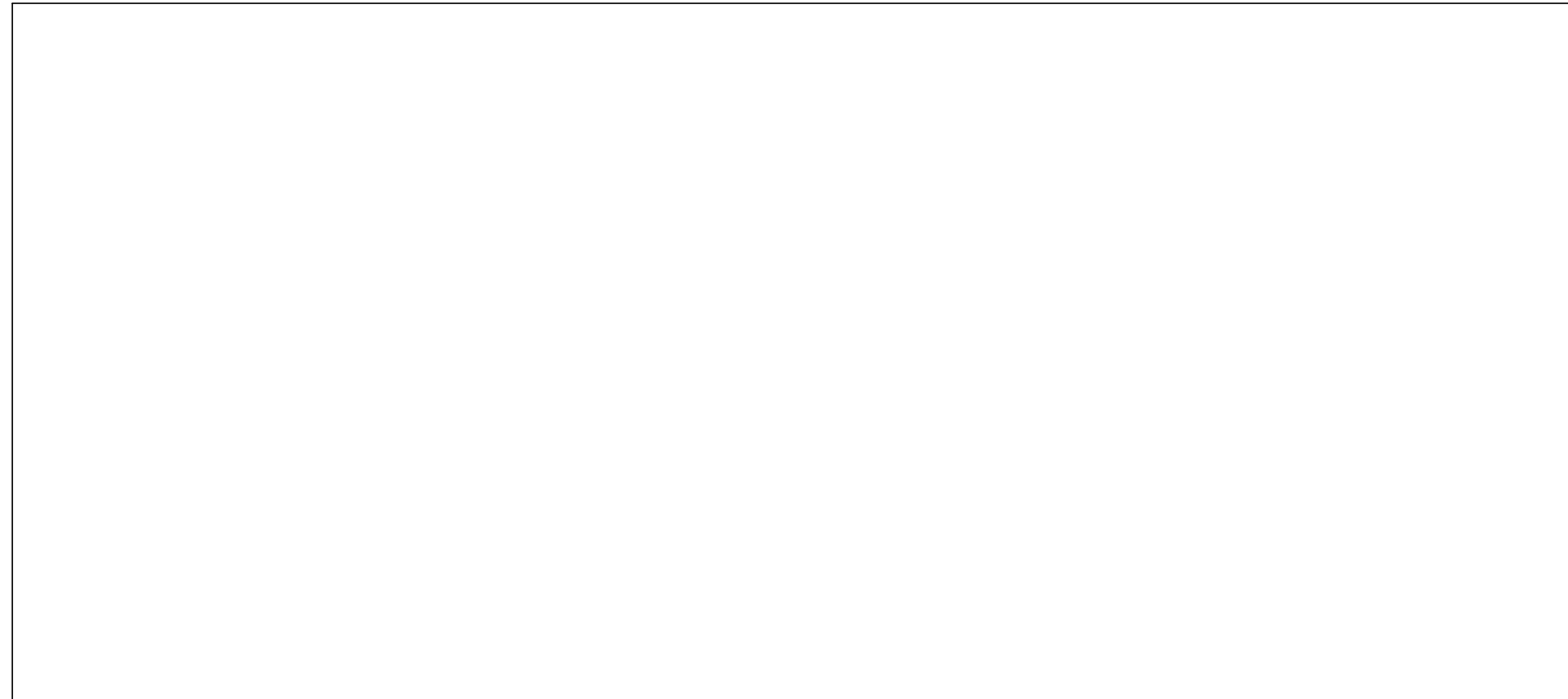

KEVIN D. MOUSTY, LICENSE #1918871
 EXPIRATION DATE 12/31/2017
 Design and construction documents as instruments of service are given in confidence and remain the property of MCG Architects. The use of this design and these construction documents for purposes other than the specific project named herein is strictly prohibited without expressed written consent of MCG Architects, Incorporated.

Date: 03-25-16 Issue for Permit



INTERIOR ELEVATION
 TEAMSPTS SCALE 3/16" = 1'-0" E9

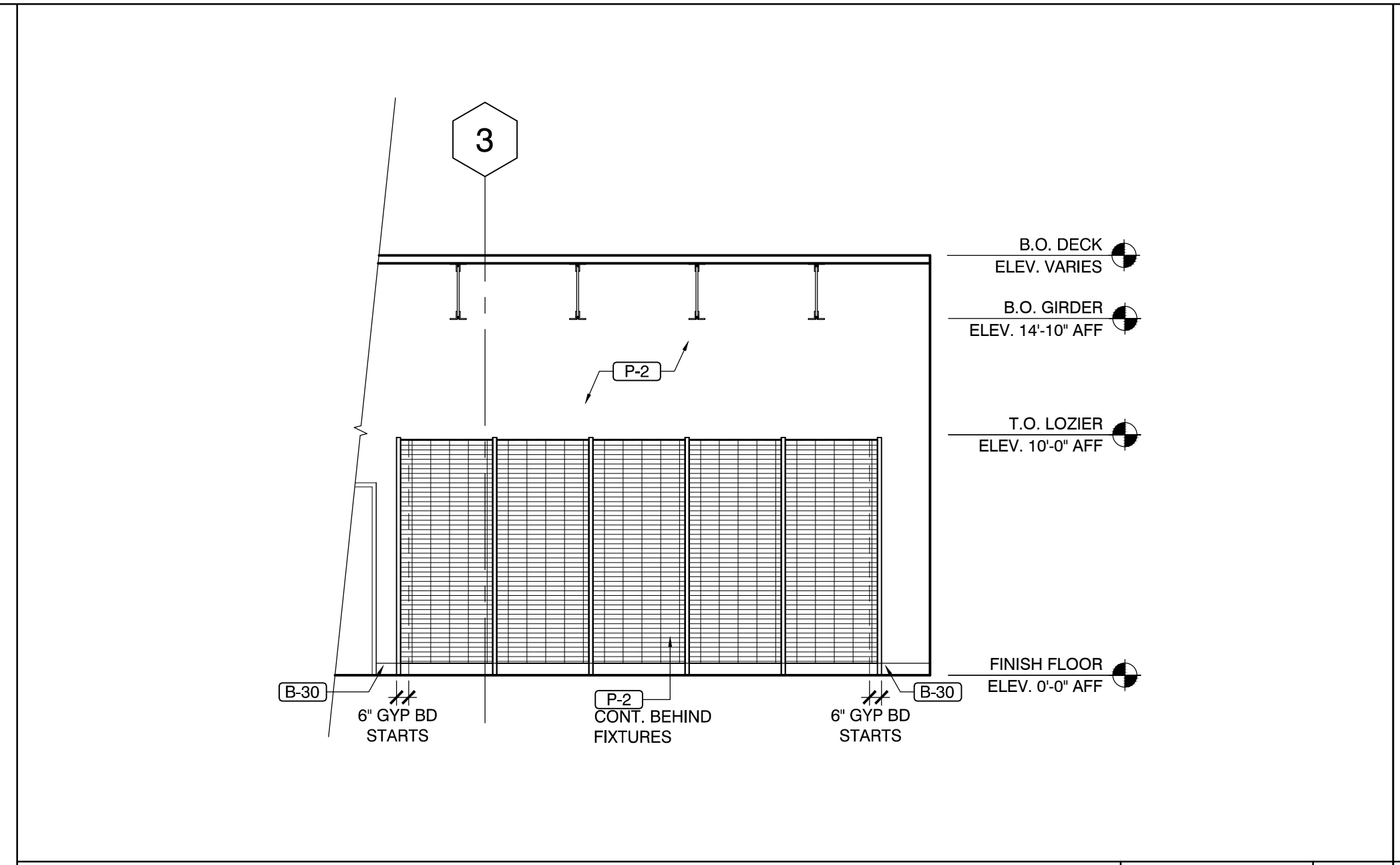

INTERIOR ELEVATION
 TEAMSPTS SCALE 3/16" = 1'-0" E8

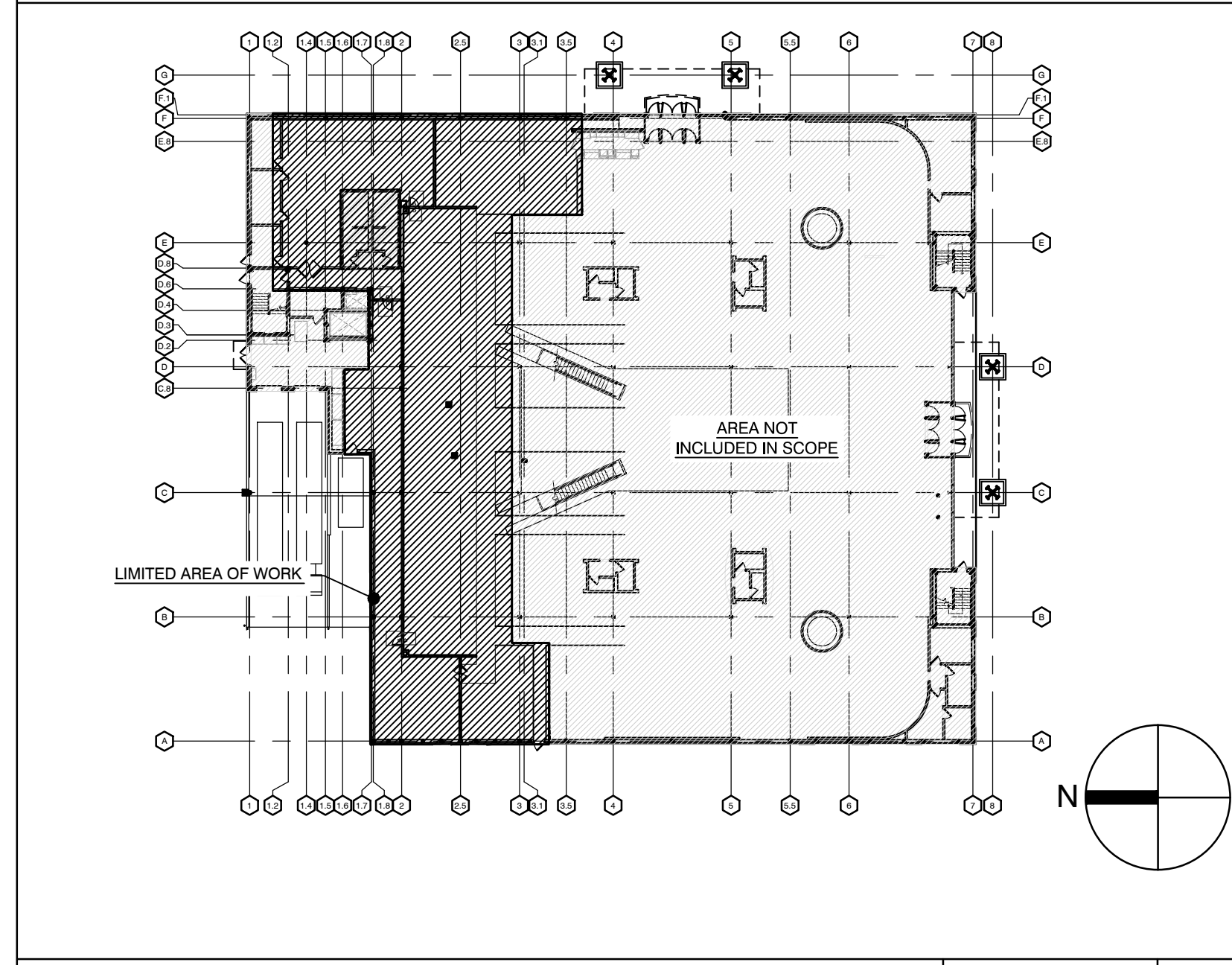

KEY PLAN
 SCALE NTS KP1

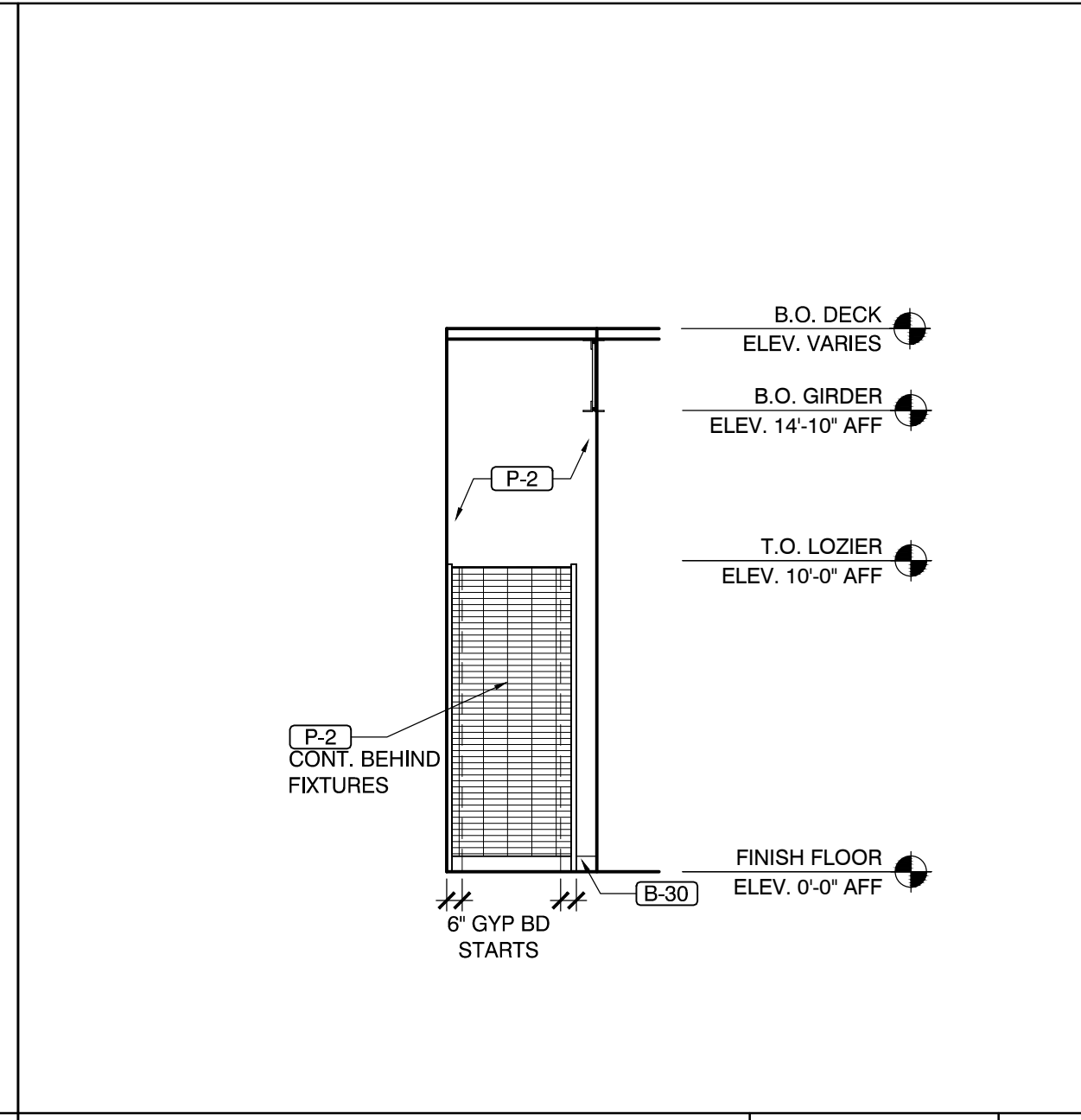

INTERIOR ELEVATION
 TEAMSPTS SCALE 3/16" = 1'-0" E7

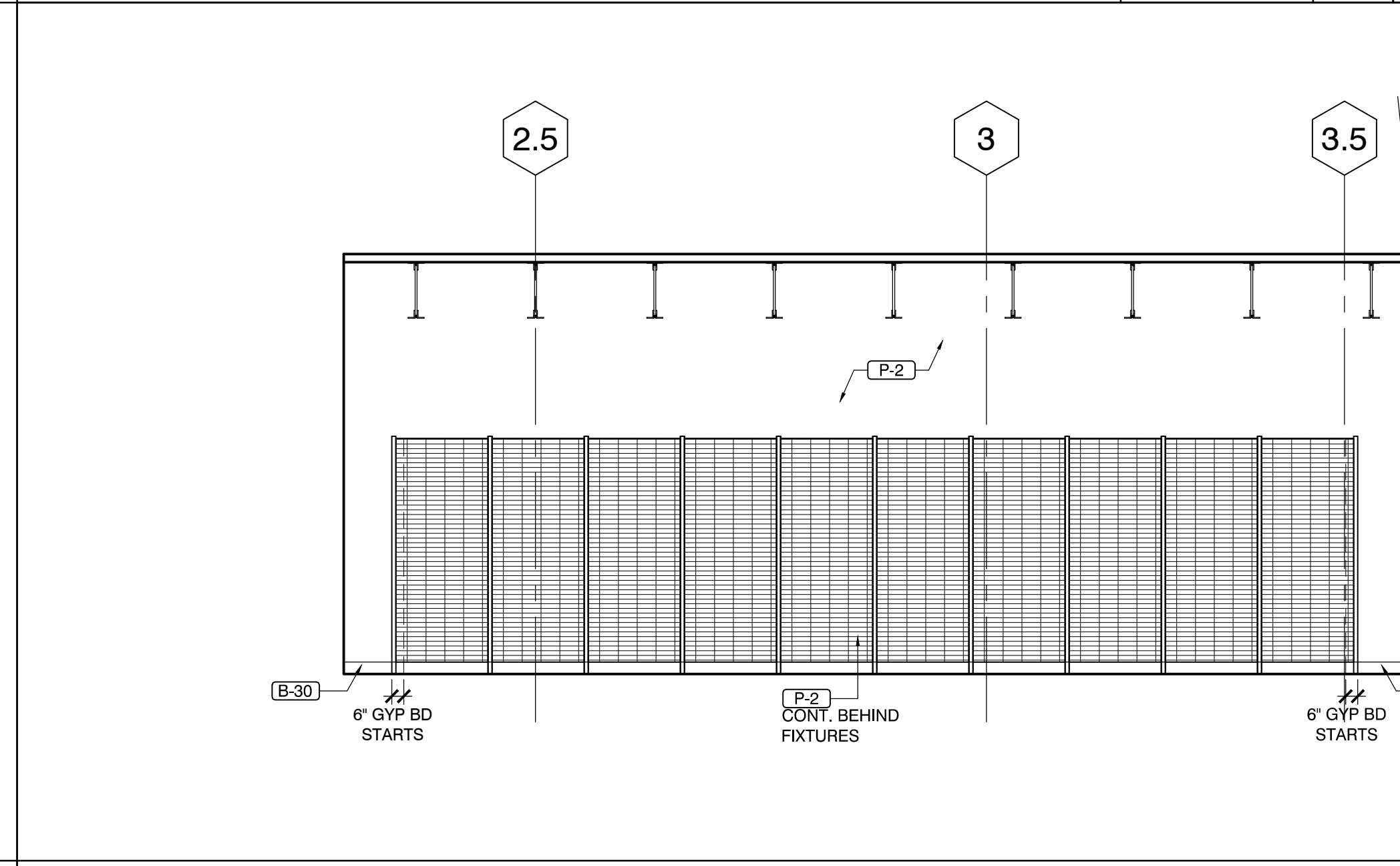

INTERIOR ELEVATION
 CASHWRAP SCALE 3/16" = 1'-0" E6

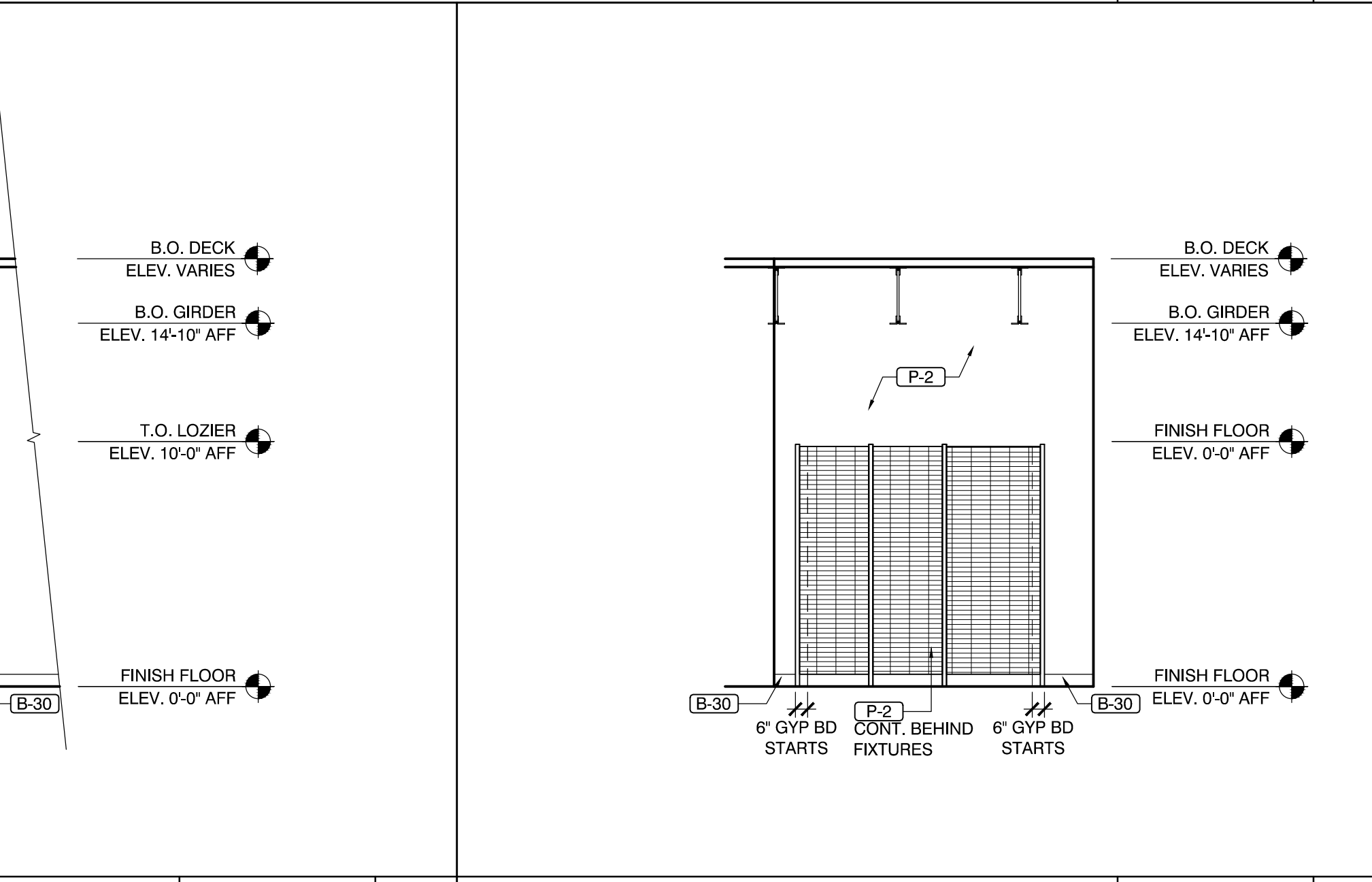

INTERIOR ELEVATION
 CASHWRAP SCALE 3/16" = 1'-0" E5

| INTERIOR FINISH SCHEDULE | | UPDATED: 03.15.2016 | |
|-------------------------------------|-----------------------------------|---------------------|--|
| (P-2) PAINT - GRAY MATTERS | (P-78) PAINT - IRON ORE | | |
| (P-11) PAINT - RAVE RED | (P-112) SSFW PAINT - AMAZING GRAY | | |
| (P-33) PAINT - HARTFORD (DSG) GREEN | (E-30) 6" VINYL COVE - BLACK | | |

NOTE: REFER TO ROOM FINISH SCHEDULE FOR ADDITIONAL FINISHES.

INTERIOR FINISH SCHEDULE
 SCALE NTS FS

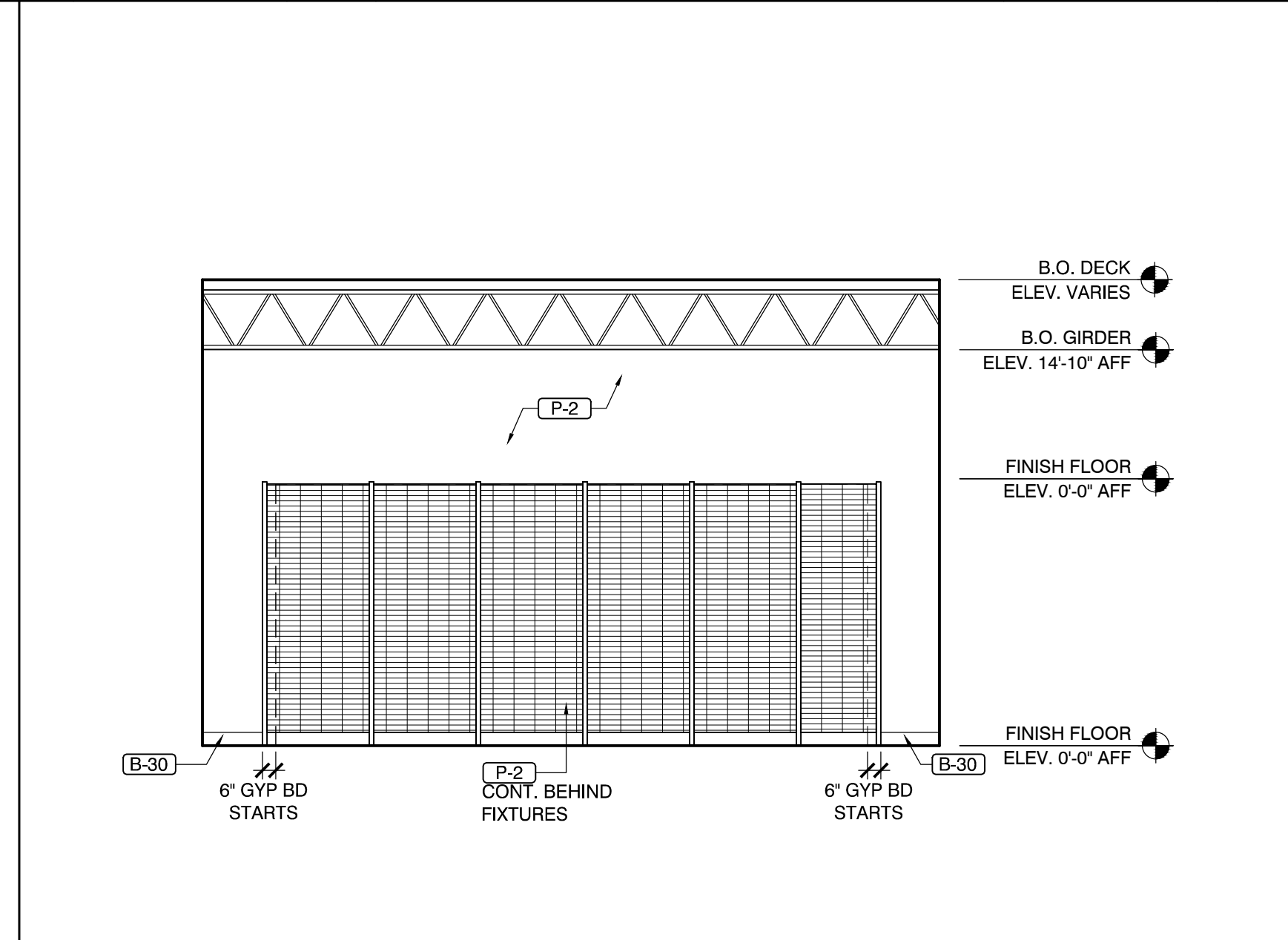

INTERIOR ELEVATION
 CASHWRAP SCALE 3/16" = 1'-0" E4

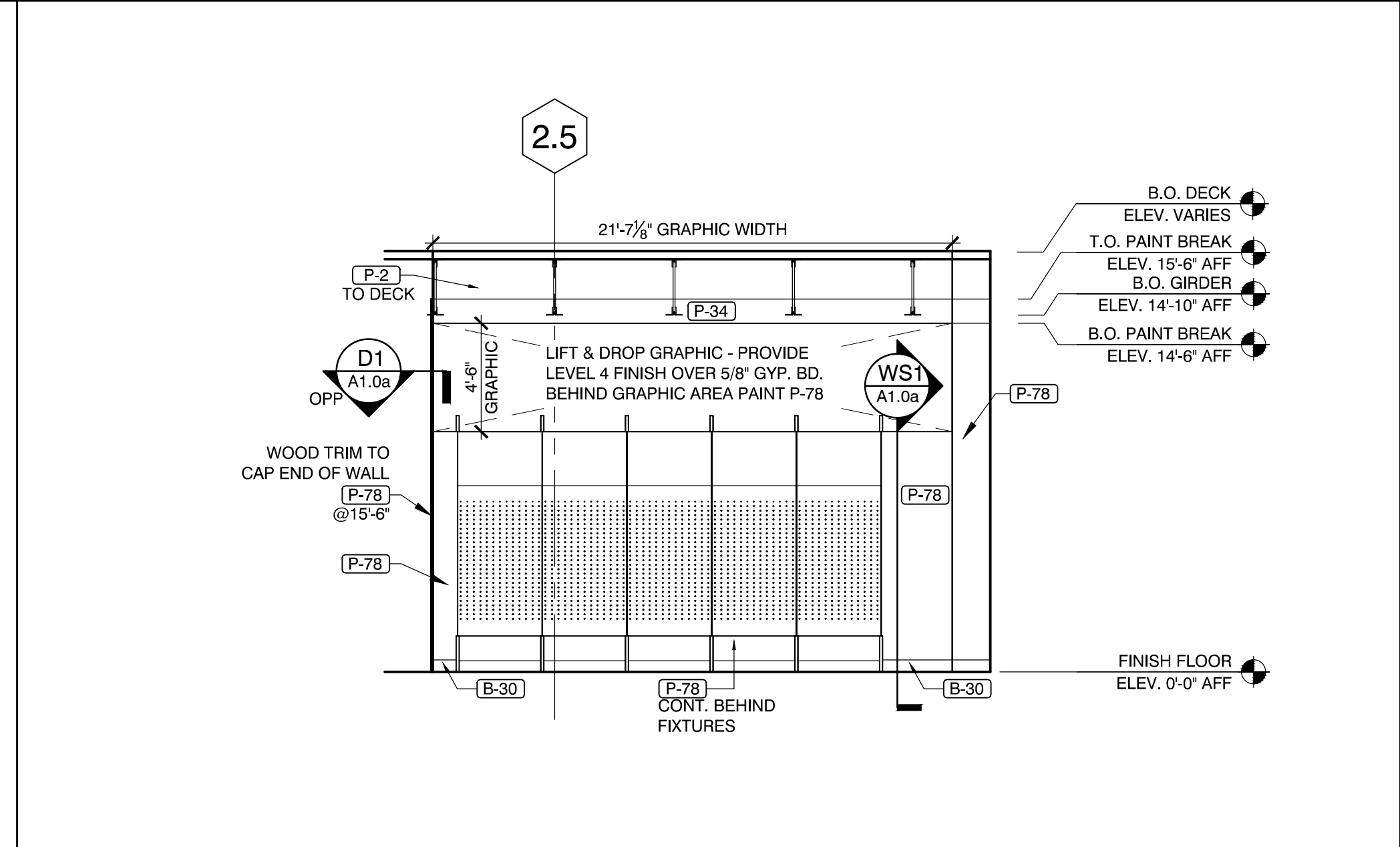

INTERIOR ELEVATION
 FOOTWEAR SCALE 3/16" = 1'-0" E3

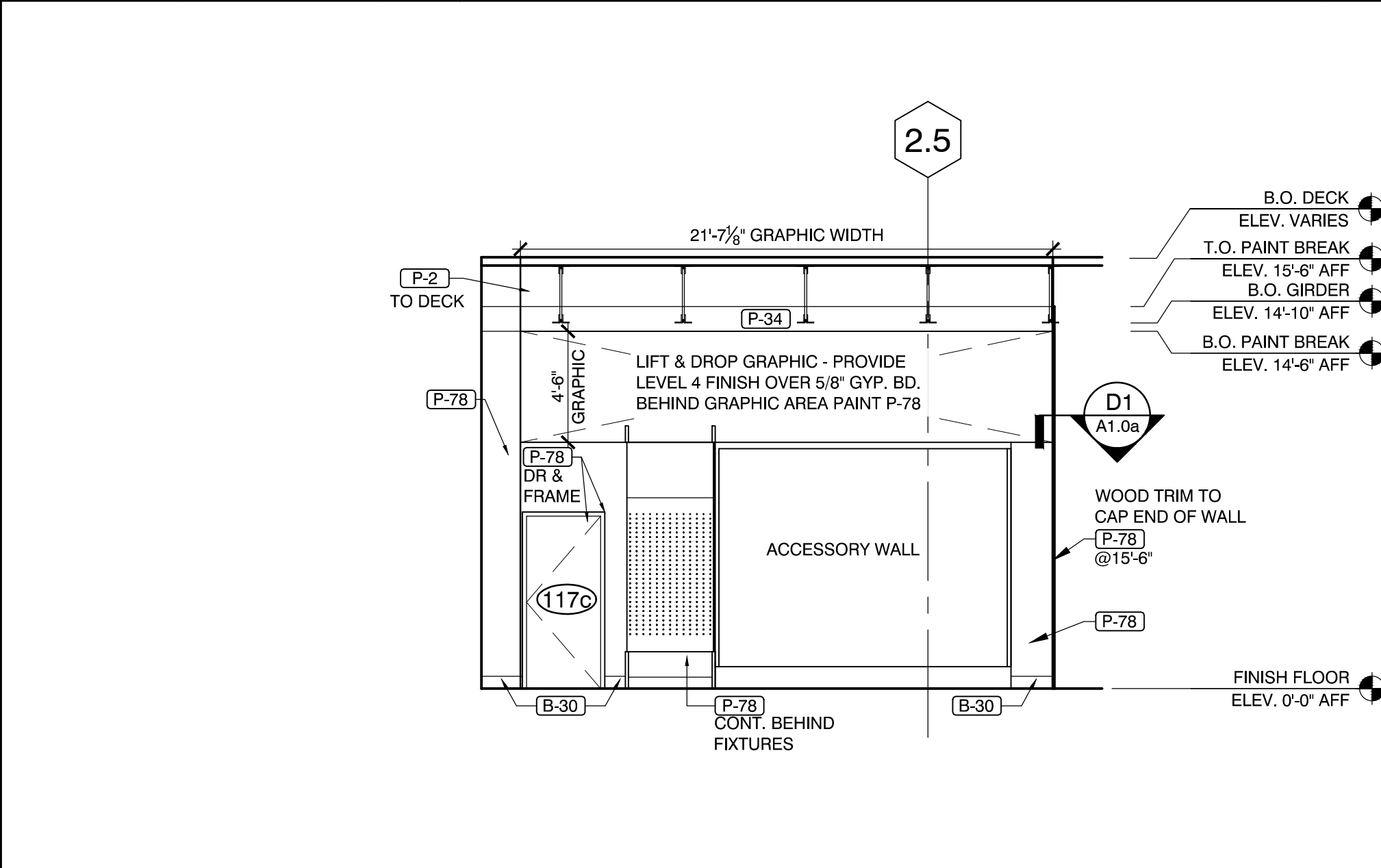

INTERIOR ELEVATION
 FOOTWEAR SCALE 3/16" = 1'-0" E2

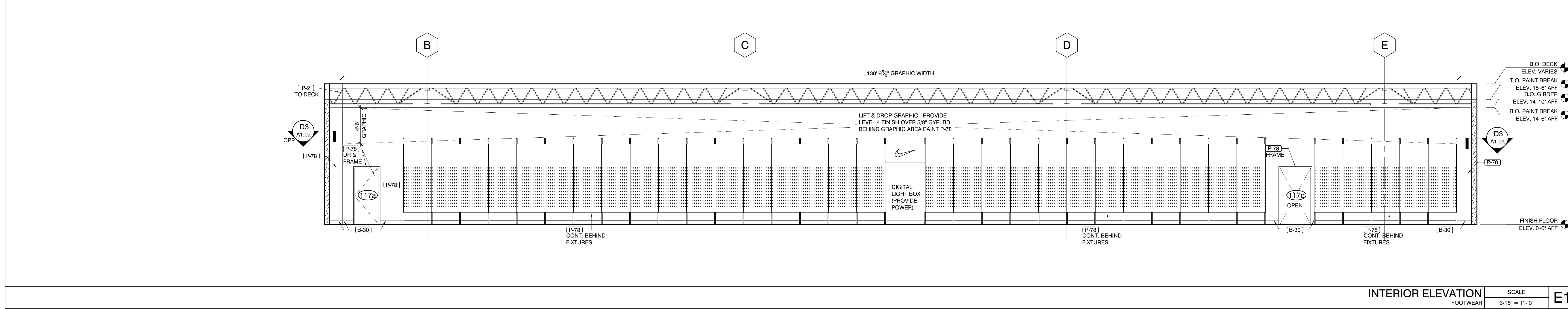

INTERIOR ELEVATION
 FOOTWEAR SCALE 3/16" = 1'-0" E1

Drawn By: MCG

Project No.: 16101.10

DICK'S SPORTING GOODS STORE # 434
 LEGACY VILLAGE
 24545 CEDAR ROAD
 LINDHURST, OH 44124

*All work, materials, and systems shown in these plans and specifications, including all referenced national accounts is the sole responsibility of the General Contractor to purchase, schedule, and install complete as shown in these plans and/or specifications. **

DICK'S
 LEGACY VILLAGE
 24545 CEDAR ROAD
 LINDHURST, OH 44124



216.520.1551 216.520.1567
 7100 E. Pleasant Valley Rd., Suite 320, Cleveland, OH 44131

INTERIOR ELEVATIONS AND DETAILS
A12.0